

Appendix D Pallet and Slipsheet Specifications

Lowes' Pallet Specifications: Regional Distribution Center Pallet Requirements.

Purpose: To develop a standard 2 or 4-way (GMA) pallet specification to be used at Lowe's Regional Distribution Center locations. The construction of the pallet must be accessible for all forklift equipment to facilitate handling throughout the entire distribution process.

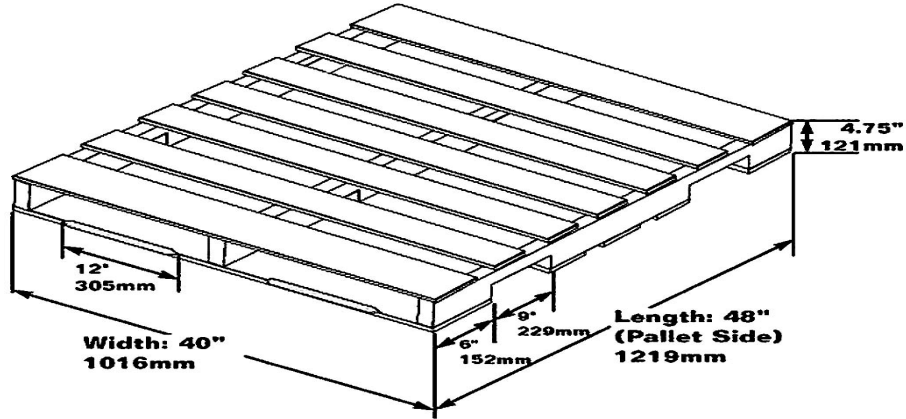

<ul style="list-style-type: none"> • Pallet Dimensions (L x W): 	<p>Length = 48.00 inches. Width = 40.00 inches.</p>
<ul style="list-style-type: none"> • Pallet Style: 	Double Faced Non-Reversible.
<ul style="list-style-type: none"> • Entry: 	2 or 4-way entry.
<ul style="list-style-type: none"> • Lumber Specifications: 	Grade III and/or IV hardwood, clean sawn.
<ul style="list-style-type: none"> • Fastener Requirements 	2.00 inch screw shank nails.
<ul style="list-style-type: none"> • Top Deck Boards (7/pallet): 	<p>Outer Boards (2) = 0.625 x 5.75 x 40.00 inches. Inner Boards (5) = 0.625 x 3.75 x 40.00 inches. Space between boards: 3 inches (max.)</p>
<ul style="list-style-type: none"> • Bottom Deck Boards (5/pallet): 	<p>Outer Boards (2, chamfered) = 0.625 x 5.75 x 40.00 inches. Inner Boards (3) = 0.625 x 3.75 x 40.00 inches.</p>
<ul style="list-style-type: none"> • Runners (3/pallet): 	1.50 x 3.50 x 48.00 inches.

Notice: Pallets requiring an alternative style or dimension due to product size limitations or for product protection, must be reviewed and approved by the Promotional display Specialist or Merchandising Organization at Lowe's Companies, Inc.

Important: If the weight of the pallet load exceeds the capabilities of the above specification, it is the responsibility of the vendor to determine if additional runners or deckboards are required to safely support the palletized load.

Slip Sheet Specification for Regional Distribution Centers

General:

- **Lowe's Regional Distribution Center's minimum standard slip sheet is 43" width by 51" length having two adjacent tabs of 3" each. The slip sheet is made of high density polyethylene 100% recycled raw material base with a minimum tensile strength of 2,100 psi and tear test of 14 pounds.**
 - Slip sheets size is set to conform to Lowe's Distribution Center rack system
 - Slip sheets for loads exceeding 48" in length must be coordinated with Lowe's Vendor Logistics Specialist
- Vendor must consult with a slip sheet manufacturer to certify that slip sheets meet or exceed Lowe's standards.

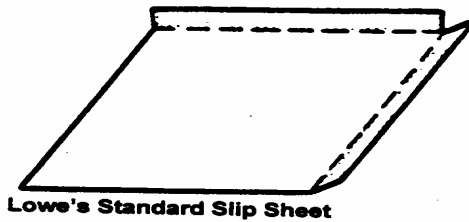

Slip Sheet Specifications (minimum):

- Materials: - High density, polyethylene (HDPE) 100% recycled raw material base with a minimum tensile strength of 2,100 psi and tear test of 14 pounds
- Size: - 43" X 51" counting 3" side and end tabs (40" X 48" footprint)
- Gauge / Thickness:
 - Loads less than 1,800 lb. 20 mil
 - Loads 1,800 lb. to 2,400 lb. 25 mil
 - Loads 2,400 lb. or greater 30 mil
- Pull Tabs: - Two, three inch (3") adjacent side and end pull tabs
- Corners: - Split, 90 degree, or diagonal corners engineered to meet product specific requirements.
- Friction Properties
 - Load side of sheet - non skid laminate with a coefficient of friction (COF) equal to or greater than .49 to minimize product movement.
 - Bottom side of sheet - matte finish to facilitate load movement
- Optional Features
 - To customize slip sheets to specific unit load and unique operational procedures, the following are permitted:
 - Locking tray, pre-punched stretch wrapped starter hole, and pattern designs (e.g. dimple or waffle)
 - Four, three inch tabs consisting of 2 fold tabs for shrink wrapping around loads and 2 tabs for load handling
 - Equivalent gauges to tensile strengths for loads less than 1,800 lbs. as an exception and with certification (Example: 16 mil with a tensile strength of 3,200 lbs.)